

HIGH RESISTANCE GROUNDING – AVOIDING UNNECESSARY PITFALLS

Copyright Material IEEE
Paper No. PCIC-2007-4

David Murray, P.Eng.
Senior Member, IEEE
Schneider Electric
19 Waterman Avenue
Toronto, Ontario
Canada M4B 1Y2
david.murray@ieee.org

John Dickin, P.Eng.
Member, IEEE
Dickin Engineering Inc.
27 Oyen Crescent
Red Deer, Alberta
Canada T4P 1T3
dickinengineering@ieee.org

Robert Hanna, PhD, P.Eng.
Fellow, IEEE
RPM Engineering Ltd.
2816 Hammond Road
Mississauga, Ontario
Canada L5K 2R1
r.hanna@ieee.org

Tom Morin, C.E.T.
Petro-Canada Oil & Gas
150-6th Avenue S.W.
Calgary, Alberta
Canada T2P 3E3
tmorin@petro-canada.ca

Abstract – High resistance grounding (HRG) of 480 V to 5 kV industrial power systems increases service continuity, enhances personnel safety and reduces equipment damage when a ground fault occurs. HRG allows maintenance personnel to quickly and safely locate a ground fault while avoiding unscheduled downtime. An abundance of literature has been published on HRG practices since the mid-1970s. Recent years have seen increased application and misapplication of transient voltage surge suppressors (TVSS) and uninterruptible power supplies (UPS) in HRG power systems. These misapplications and their solutions are discussed. Additionally, engineering oversights in the design of HRG systems are addressed, as well as operations and maintenance issues associated with an HRG system.

Index Terms — High resistance grounding, transient voltage surge suppressor, uninterruptible power supply.

I. INTRODUCTION

High resistance grounding of low-voltage power distribution systems in North America became popular in the early 1970's for continuous-process industries. At that time, the NEC and Canadian Electrical Code (CEC) were amended to require the main overcurrent protective device to automatically trip on ground fault on most 480 V and 600 V solidly grounded systems. The purpose of the code change was to minimize the occurrence of equipment burndowns due to arcing ground faults [1]. Prior to the 1940's, industrial power systems were ungrounded because the loads were three-wire, and service continuity could be maintained during a ground fault. During the 1940's, ungrounded low-voltage systems gave way to solidly grounded systems for the following reasons:

- o It was discovered that intermittent arcing ground faults on ungrounded systems could experience line-to-ground voltage excursions up to six times above normal, leading to multiple simultaneous motor insulation failures [2], [3]. These voltage excursions could be mitigated by solid grounding of the neutral.
- o For many industrial plants it was deemed less risky to trip a faulted circuit using the high ground fault current of a solidly grounded system, than to maintain service continuity with an ungrounded system.
- o Solidly grounded 277/480 V systems accommodated the new 277 V fluorescent ballasts, which provided more economical lighting [4].

However, solid grounding of 480 V and 600 V systems created a new challenge – low level arcing ground faults and their consequent damage [5]. HRG has proven to provide excellent protection from a low level arcing ground fault.

The HRG system is popular primarily because of the service continuity it provides during a ground fault. An added benefit is enhanced electrical safety from arc flash on a ground fault.

Numerous IEEE papers have been published since 1975 on the benefits and proper application of HRG for continuous-process industries [1], [3], [4], [6] – [12]. More recent papers have focused on the application of adjustable speed drives (ASD) [13] – [15] and UPS [16] on a HRG system. Nonetheless, the authors have encountered application pitfalls in HRG not fully addressed in the literature. Cases described in this paper include:

- o Transient voltage surge suppressors that ruptured when improperly applied on a HRG system;
- o A three-phase isolated redundant UPS that failed and subsequently lost the critical load when improperly connected to a HRG source;
- o An incompatible grounding method between the bypass input and inverter output of a three-phase UPS that exposed the critical load to risk during ground faults;
- o The need for 4-pole breakers on the output of parallel 3-phase UPS modules that are high resistance grounded;
- o A comparison of present HRG practices between parallel UPS modules and parallel generators.

Also discussed are design shortcomings in ground fault protection and alarm systems that are still prevalent in modern HRG installations. Lack of a clear and logical alarm system fails to indicate the seriousness of leaving a ground fault on the system, and provides poor navigation to the location of the ground fault. Further, unclear operating procedures leave confusion and delays in the appropriate actions when a ground fault occurs.

II. APPLICATION PITFALLS TO AVOID

A. Transient Voltage Surge Suppressors (TVSS)

In the late-1990's a transient voltage surge suppressor ruptured in a new 600 V switchboard at a data center in southern Ontario, Canada. The 600 V distribution system was high resistance grounded through a 5 A, 347 V, 69 Ω neutral grounding resistor. Investigation revealed that the TVSS, rated for a 3-phase, 4-wire, 347/600 V wye system, failed during a ground fault when the metal oxide varistors (MOVs) connected

between line-to-ground (L-G), were exposed to excessive continuous voltage on the two unfaulted phases during the ground fault. The applied voltage exceeded the rated maximum continuous operating voltage (MCOV) of the MOVs.

The TVSS was designed for use on a solidly grounded system. It had been misapplied on the HRG system. Fig. 1 shows the typical connections, and Table 1 shows the typical ratings, of MOVs in TVSS units designed for a 3-phase, 4-wire, solidly grounded systems. L-L mode MOVs are shown dotted because they are often omitted. Line-to-line protection is effectively provided though the L-N and L-G MOVs. Between any two phases there are two L-N mode MOVs in series, and two L-G mode MOVs in series.

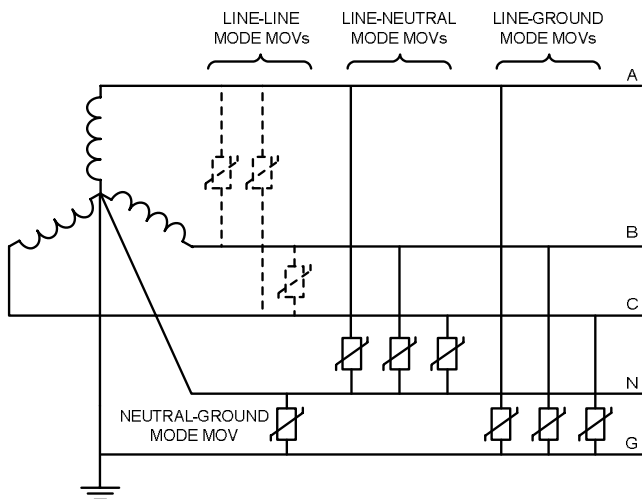

Fig. 1 TVSS for Solidly Grounded System

TABLE I

TYPICAL MCOV RATINGS FOR 3-PHASE, 4-WIRE SYSTEMS

| System Voltage | 347/600 V | | | | 277/480 V | | | | |
|----------------|-----------|-----|-----|-----|-----------|-----|-----|-----|-----|
| | Mode | L-N | L-G | L-L | N-G | L-N | L-G | L-L | N-G |
| MCOV | | 420 | 420 | 840 | 420 | 320 | 320 | 640 | 320 |

An MCOV of 420 V is sufficient for MOVs connected L-G on a solidly grounded 347/600 V system. Continuous L-G voltage does not exceed 347 V ± 10%. On a HRG system, however, L-G voltage rises to 600 V (i.e., to rated line voltage) during a bolted ground fault. At this voltage an MOV with an MCOV of 420 V will be stressed and eventually fail. That is why the MCOV of an MOV connected in L-G mode on a HRG system must be rated higher than the system line voltage. Fig. 2 shows the typical connections, and Table 2 shows the typical ratings, of MOVs in TVSS units designed for a 3-phase, 3-wire, HRG system.

In North America, 480 V and 600 V HRG systems are 3-wire. The neutral is not distributed because it becomes energized during a ground fault. Hence, there is no need for L-N or N-G protection modes on a TVSS used on a 480 V or 600 V HRG system.

HRG systems do not exhibit the six times voltage excursion above ground that could be present in ungrounded systems during intermittent arcing ground faults. The let-thru current of a

neutral grounding resistor (NGR) is always chosen to be higher

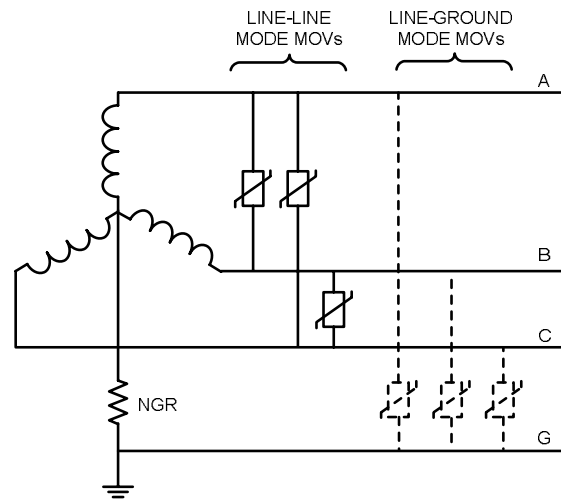

Fig. 2 TVSS for High Resistance Grounded System

TABLE 2

TYPICAL MCOV RATINGS FOR 3-PHASE, 3-WIRE HRG SYSTEMS

| System Voltage | 600 V | | 480 V | | |
|----------------|-------|-----|-------|-----|-----|
| | Mode | L-G | L-L | L-G | L-L |
| MCOV | | 750 | 750 | 575 | 575 |

than the capacitive system charging current. Hence the continuous L-G voltage during a ground fault will not exceed 600 V on a 600 V system, or 480 V on a 480 V system.

The 2005 NEC, in section 285.3(3), calls for the MCOV of a TVSS to exceed the maximum continuous phase-to-ground voltage available at the point of application. Section 285.3(2) specifies that a TVSS used on a resistance grounded system be listed for use on this type of system.

It is anticipated that UL 1449, Transient Voltage Surge Suppressors, will also have to be amended to add a listing for use on resistance grounded systems. When published, it is expected that the UL listing will remove some of the ambiguity in applying a TVSS to a HRG system. Until such a listing is available by UL, one must use what is known as a "delta-rated" TVSS, which is suitable for use on a HRG system.

MOVs in a delta-rated TVSS are typically connected in L-L and L-G mode, as shown in Fig. 2. L-G mode is shown dotted because some TVSS manufacturers offer delta-rated units with L-L mode MOVs only. Typical MCOV ratings are shown in Table 2.

It is not recommended that TVSS's be installed in delta ungrounded distribution systems due to the possibility of excessive phase-to-ground voltages that can occur during intermittent arcing ground faults. These voltage excursions would rupture a TVSS. Instead, as shown in Fig. 3, an ungrounded delta system should be converted to a HRG system by connecting an artificial neutral zig-zag grounding transformer and NGR. Conversion to a HRG system is relatively economical and eliminates the possibility of excessive voltages to ground during intermittent arcing ground faults. After conversion, a TVSS may be installed as shown in Fig. 3.

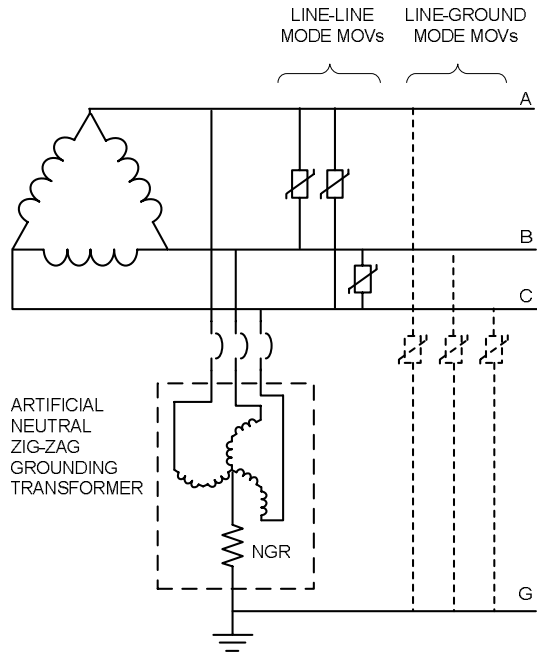

Fig. 3 High Resistance Grounding of a Delta System

B. Supplying a 3-Phase UPS from a HRG System

UPS systems designed for use on solidly grounded systems often employ MOV surge suppressors at the rectifier input. The phase-to-ground MCOV is typically insufficient for application on a HRG source. A typical UPS will include either a rectifier input autotransformer, or possibly no transformer at all. Connecting this type of UPS to a HRG source can result in failure of the rectifier MOVs and loss of power to the critical load.

When purchasing a 3-phase UPS System, the UPS manufacturer should be informed whenever the UPS is to be fed from a HRG power source. They will provide the UPS with a rectifier input isolation transformer to prevent the rectifier MOVs from being exposed to high phase-to-ground voltages during a ground fault on the upstream power source.

Due to the possible presence of excessive phase-to-ground voltages on ungrounded systems, consideration should be given to converting ungrounded systems to HRG before installing a UPS or an ASD.

C. Failure of Isolated Redundant UPS with HRG System

For this application, the critical load was protected using dual 150 kVA rated UPS modules, connected in an isolated redundant configuration, as illustrated in Fig. 4. The primary module is normally in service, while the secondary module is on "hot standby". Upon loss of the primary unit, the critical load

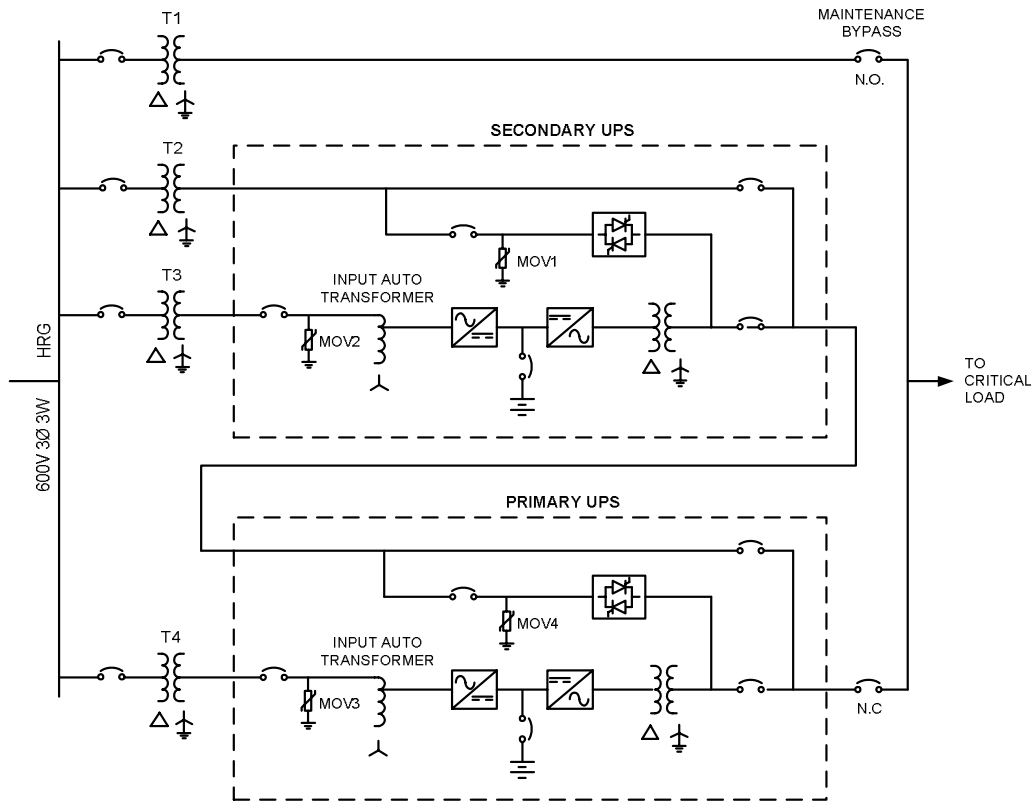

Fig. 4 Simplified One Line Diagram for Isolated Redundant UPS System.

Isolation Transformers T1, T2, T3, and T4 were added on-site later to address the problem of UPS failure.

is automatically transferred to the secondary module via the static bypass switch in less than ¼ cycle.

Each UPS module was originally factory supplied with an input autotransformer and MOVs that were connected on the 600 V side to provide transient voltage surge protection. The utility power is received at 27,600 V and stepped down to 600 V using a 750 KVA transformer with a star-connected secondary winding. The transformer neutral point is grounded via a 5 A, 69 Ω, 347 V HRG system, to provide supply continuity during a single line-to-ground fault.

The UPS system suffered a serious failure in which the primary module, its internal static bypass and the secondary module all failed, resulting in a total loss of power to the critical load. The follow up investigation revealed that the factory-installed MOVs were inadequate for application with the HRG system. The MOVs were rated at 420 V maximum continuous operating voltage (MCOV). Under normal operating conditions, the applied voltage to all MOVs is 347 V (line-to-ground) and this is well within the MCOV. Under a phase-to-ground fault condition, the voltage of the faulted phase went to zero, while the voltage of other two phases increased to 600 V, thus overly stressing the MOVs. In this case, the MOV3 that was connected to the primary module exploded, producing plasma material that shorted MOV4 on the static bypass. This occurred because the printed circuit boards for MOV3 and MOV4 were physically located three inches apart, with no adequate barrier between them.

To mitigate this problem, four input isolating transformers, T1 thru T4, were installed, each having a delta connected primary and a star connected secondary, as shown in Fig 4. The neutral of the secondary winding of each transformer was solidly grounded to ensure that the impressed voltage across the MOVs would not rise during a ground fault on the primary side 600V HRG system. Also, a proper mechanical barrier was added between the circuit boards for MOV3 and MOV4 as well as between MOV1 and MOV2.

D. Grounding of UPS Bypass Input and Inverter Output

Large UPS systems often have a bypass input power source that is separate from the rectifier input power source, for extra reliability. In the late 1990s such a single-module system was installed in a data center in Toronto, Canada, rated 600V. Both the rectifier input and bypass input power sources were high resistance grounded. The rectifier was supplied with an input isolation transformer. However, the UPS module output was solidly grounded. The UPS vendor was not informed that the building was high resistance grounded.

The first indication of a problem was the appearance of a “Bypass Unavailable Alarm” which would not disappear. Investigation revealed the presence of a ground fault in the building HVAC system that was fed from the same power transformer as the UPS bypass circuit. Once the ground fault was located and repaired, the alarm cleared.

Further investigation revealed another problem with this grounding scheme. When a ground fault occurs on the solidly grounded system that supplies the critical load, the UPS, as designed, would instantly transfer the load to bypass via the static bypass switch, in order to clear the fault. The bypass source, being HRG, would then reduce the ground fault current to 5 A or less, as per the amperage rating of the NGR. The bypass neutral voltage would rise to 347 V above ground.

Meanwhile, the inverter output, being disconnected from the faulted critical load after transfer, would have its neutral voltage at ground potential. The UPS static bypass transfer logic would prevent the critical load from being transferred back to inverter because of the difference between the neutral-to-ground voltages. As a result, the critical load would remain in bypass mode whenever a ground fault occurred in the solidly grounded system of the critical load, posing an unacceptable risk of downtime.

It was recommended that the bypass and inverter output sources be grounded same way, either solidly grounded or HRG. Typically, if the building distribution system is HRG, then the UPS inverter output should also be high resistance grounded. In this way, a ground fault in the critical load would not result in a transfer to bypass, but merely produce an alarm.

Fig. 5 shows how to properly configure a UPS for a high resistance grounded system. NGRs are added at the UPS rectifier input, Bypass input and Inverter output (NGR1, NGR2 and NGR3).

Ground alarm relays are required for each NGR, to provide alarm indication during ground fault.

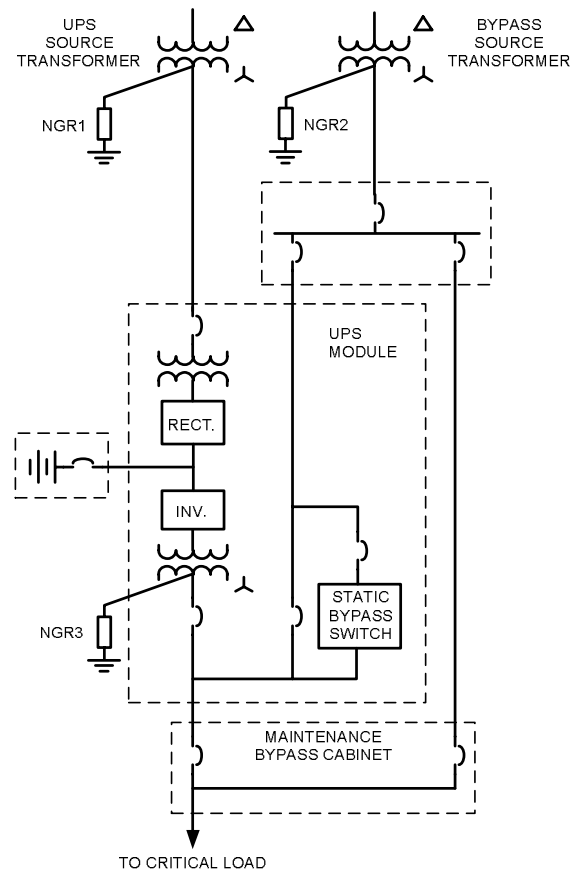

Fig. 5 Grounding of UPS Bypass Input and Inverter Output

E. High Resistance Grounding of Parallel UPS Modules

Parallel UPS modules are used to increase the redundancy and capacity of a UPS system. UPS systems have traditionally been solidly grounded at their output. A recent trend has been

to use HRG UPS systems instead, as this increases the availability of the critical bus when a ground fault occurs.

Fig. 6 illustrates the method presently preferred by UPS vendors to high resistance ground the output of a parallel UPS system. 4-pole module output isolation breakers are used to isolate the neutral when disconnecting a UPS module from the critical load, as the neutral becomes energized during a ground fault in the critical load system.

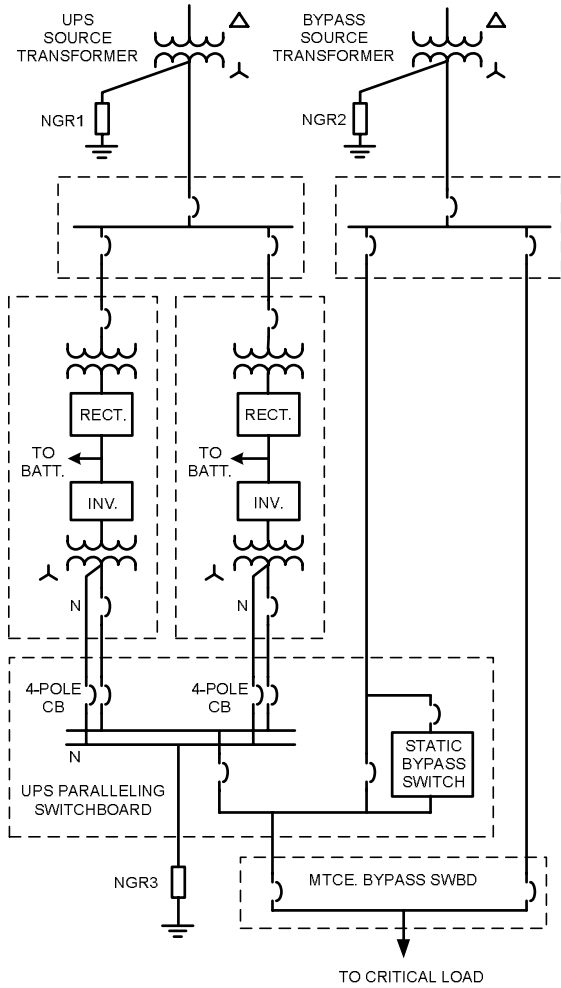

Fig. 6 High Resistance Grounding of a Parallel UPS System

Solidly grounded parallel 480 V or 600 V UPS systems must share a common neutral bus at the output even though most critical loads are three-wire, because the UPS system neutral can only be grounded at one point. Significant circulating currents flow in the shared neutral; hence most UPS manufacturers recommend a full capacity neutral cable.

For a HRG system, UPS manufacturers adapt the traditional solid grounding scheme of the shared neutral cable by connecting a neutral grounding resistor (rated 2-5 A) between the neutral bus and ground, shown as NGR3 in Fig. 6. The neutral bus becomes energized during a ground fault. When a UPS module is disconnected from the critical bus for maintenance, it is not sufficient to disconnect the module phase conductors with a 3-pole breaker – the neutral must also be

disconnected. Hence 4-pole breakers are used. Otherwise the secondary windings of the UPS module output transformer could become energized during a ground fault in the critical load system.

It is interesting to compare the HRG methods presently used in parallel generators and parallel UPS modules. In common, both systems consist of wye-configured output windings connected in parallel. Additionally, when there is a shared neutral between parallel generators or parallel UPS modules, significant circulating current typically flows in the neutral, even when the load is 3-wire.

However, one difference between UPS output transformers and generators is that generators naturally exhibit low zero sequence impedance. Hence, it has long been recommended that generators be resistance grounded to limit damaging ground fault currents [17], [18]. Low zero sequence impedance also causes excessive neutral circulating current in parallel generators. Fig. 7 illustrates a common method for high resistance grounding parallel generators that prevents excessive circulating neutral currents and limits ground fault current to a safe value. Instead of directly connecting an NGR to a common neutral terminal, an artificial neutral zig-zag grounding transformer is connected to the three-phase

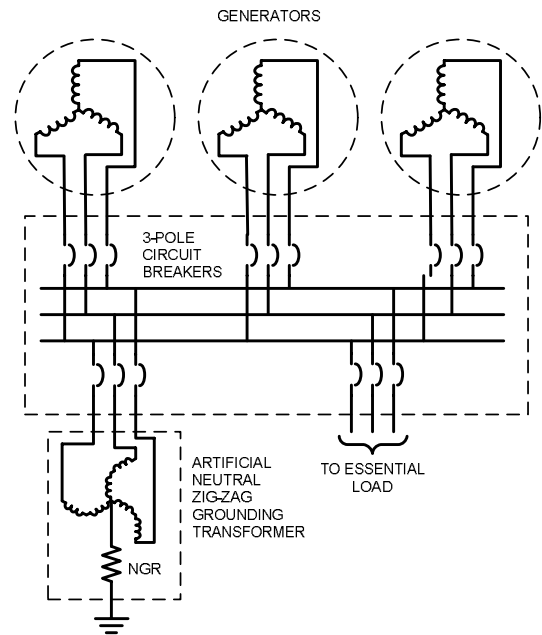

Fig. 7 High Resistance Grounding Scheme of Parallel Generators

paralleling bus. The neutral point of the grounding transformer is then grounded through an NGR. With this method of grounding, 3-pole breakers are sufficient to isolate the generators, and 4-pole breakers are not required.

UPS manufacturers specify that a shared neutral conductor be interconnected between the outputs of parallel UPS modules for both a solidly grounded system output and a HRG system output. A shared neutral is necessary for solidly grounded parallel UPS modules, as it is for solidly grounded parallel generators, to ensure that the system output neutral is grounded at only one point.

By contrast, generator suppliers do not require a shared neutral when the system is high resistance grounded via an artificial neutral zig-zag grounding transformer, which eliminates the need for 4-pole generator breakers.

It is suggested that UPS manufacturers should consider the grounding scheme widely used on parallel generators as shown in Fig. 7. Then, 4-pole breakers will not be required and switchgear construction would be simpler.

III. SUBMERSIBLE PUMPS

HRG is known to reduce the shock hazard in a bonded metal ground return path by reducing ground fault current and associated touch voltage [12]. However, if a submerged pump circuit were to fault to the surrounding liquid, the ground fault return path could inadvertently include the liquid. In such case, the resistance of the liquid could limit ground fault current below the pickup setting of the HRG ground alarm relay. If the liquid were exposed, it would be possible for personnel to receive a shock by touching the liquid, even though the ground fault may be undetected by the ground fault relay.

In 2006 an electrician experienced a non-injurious electric shock at a fertilizer plant in the US, which required prompt investigation. The plant 480 V system was high resistance grounded with a 5 A, 55 Ω neutral grounding resistor. An open metal vat of liquid had a three-phase, 480 V submersible pump fed from a motor control center starter, complete with a ground fault relay. The metal vat was grounded. The ground fault relay had an alarm pickup setting of 2 A and trip pickup setting of 6 A. The pickup settings were chosen so as to alarm only on a single ground fault, and to de-energize the feeder upon a double ground fault between two feeders and two different phases (a phase-to-ground-to-phase fault). The ground fault relay was not in alarm, yet the electrician received a shock when he touched the liquid in the vat. It was questioned why the HRG system had failed to alarm when there clearly had been a ground fault.

Investigation revealed a pinched electrical cable at the pump connection. This insulation fault, in series with the liquid in the vat, had enough resistance to limit the ground fault current to less than 2 A. There was not enough fault current to activate the ground alarm relay. The pinched cable was repaired and the entire feeder circuit was tested for insulation resistance to ground to ensure that the problem was solved.

The ground fault reminded the facility engineer that a typical HRG ground alarm pickup setting was not rated for personnel protection.

If a sensitive ground fault relay was installed in the submersible pump feeder, it would provide much earlier warning of insulation failure than a typical HRG ground alarm pickup setting. 600 V, 30 mA ground fault relays are commercially available to detect leakage current due to insulation failure.

IV. ENGINEERING OVERSIGHTS IN DESIGN

The lack of true understanding of three key design aspects has been observed in a number of installations and designs where HRG systems are designed to alarm on the first ground fault only. These are:

- o Providing proper ground fault protection for the second ground fault on another phase.

- o Providing logical ground fault alarm location systems.
- o Providing proper operation procedures.

A. Backup Ground Fault Protection

It is not an uncommon procedure (though not recommended) to ignore the first ground fault on systems rated 600V and below as there is no immediate effect to production or plant operation. With this practice, there is an increased risk of the fault escalating into a double phase to ground fault. Backup ground fault overcurrent relaying [19] [20], zone selective interlocking [19], or selective instantaneous feeder tripping [9] are recommended to provide fast detection of a double phase to ground short circuit current, and to trip the faulted circuit or circuits off line at a speed faster than phase overcurrent protection. Waiting for the phase overcurrent protection to pick up the fault will increase the time the fault exists [20] and increase the arc flash risk.

Further, not responding in a timely manner to a ground fault alarm on systems at higher voltages will, in a very short time, progress to a double phase to ground or three phase to ground fault. It is recommended that the same protection additions listed above (backup ground fault overcurrent relaying, zone selective interlocking, or selective instantaneous feeder tripping), be incorporated into the design.

B. Ground Fault Alarm System Design

The application of using HRG systems has in effect replaced the automatic tripping function of ground fault relays with the manual fault clearing (tripping) function completed by the plant operations and maintenance workers. Tripping the faulted equipment off line is an eventuality and including human intervention into the decision on when and how should reduce the plant upset risks and production loss.

It is important that the designer consider the ground fault alarm system as part of a safety system requiring identification and location of the ground fault hazard. The designer should consider this function as critical and it should be managed with a higher priority than the many other less important electrical alarms that could be addressed with less haste. The alarm descriptors should indicate the location where the ground fault current was sensed. The more locations where the ground fault current is sensed and annunciated, the less time is spent narrowing down the location of the ground fault. The extent and complexity of the alarm system should only be limited by the complexity of the system.

C. Ground Fault Operating Procedures

Typically, the occurrence of a ground fault is rare, and it is reasonable to assume the workers who acknowledge and respond to the ground fault alarm will not be fully conversant on the issues and responses to a ground fault alarm. It is recommended that a ground fault alarm be treated as a critical one, and to be managed with an operating procedure that is regularly reviewed. The operating procedure should be developed concurrently with the alarm system design, so as to optimize the number and location of the ground fault current sensing relays. Additional aspects of the operating procedure are covered in the next section.

V. OPERATION AND MAINTENANCE

Whether a HRG system is implemented in a new facility, or is introduced as a change to an existing facility, education and training of applicable personnel are required for safe operation and maintenance, which contributes to increased reliability of the facility.

With respect to maintenance, electricians may not be familiar with the operational characteristics of the system. Confusion between the potential of the neutral and ground (i.e., believing that they are the same point electrically) could have serious consequences. Similarly, misunderstanding the magnitude of the voltage drop across the resistor could result in damaged test equipment or personnel injury. The most experienced maintenance personnel, likely the older and longer-serving employees, may not have been schooled in HRG systems during their apprenticeship. Introductory training, with periodic review, is necessary to ensure that personnel are aware of the operation of the system and procedures required for safe maintenance.

HRG systems can greatly contribute to the reliability of a production facility by providing a window-of-time for personnel to locate and isolate faulted equipment prior to a unit or plant trip. With the aid of a logical alarm system, operating procedures, and ground fault locating equipment, personnel can navigate towards the faulted device and remove it from service.

Regardless of the process generalized above, prudent management would imply that electrical maintenance personnel be instructed in the operational characteristics of the system and provided with a detailed and comprehensive work procedure that should include expanded interpretations of the alarm descriptors, and step-by-step procedures that detail the investigation and isolation of the faulted equipment, including the time-to-trip and consequences of a trip (i.e., plant, unit or equipment shutdown). Time-to-trip and the associated consequences will dictate the urgency of the incident.

Navigation to the faulted device can be assisted by the use of fault tracking equipment (tracking signals or pulses impressed on the ground system and the use of hand held sensing equipment) [1], [2], [8], [11], [19], [20]. This equipment usually requires a signal sensing probe or clamp to be placed in contact or in the vicinity of the system power conductors. As operating procedures become more established with respect to the prevention of shock and arc flash injuries, the use of this kind of equipment may become more difficult to use. Occupational health and safety regulations may require the workers wear more than the minimum of Personal Protective Equipment and follow detailed work procedures if it is deemed a high risk procedure. It may be more appropriate to ensure the design of the ground fault system has adequate sensing locations that can be accessed safely. In addition, it would be possible to add additional zero sequence current transformers (ZSCT's) to existing equipment where the number of sensing locations are inadequate for the needs of the plant. Split core ZSCT's are available for retrofit applications.

The scale of the implementation of maintenance and operating procedure will vary throughout and within industries. However, the necessity of a procedure that educates personnel in the electrical and operational characteristics of the system should be the first priority.

VI. CONCLUSIONS

High resistance grounding offers excellent protection against arcing ground faults and unscheduled shutdown from ground faults. However, care must be taken when connecting devices and equipment such as transient voltage surge suppressors and uninterruptible power supplies to a HRG system, so as to avoid unscheduled downtime. In addition, operational and maintenance aspects should also be considered. The following are key factors that should be considered when implementing a HRG system:

- o Transient voltage surge suppressors should be rated for use on HRG systems. Three-wire "delta-rated" TVSS are suitable for use on 480 V or 600 V HRG systems. It is not recommended to use a "wye-rated" 277/480 V or 347/600 V TVSS on HRG systems.
- o A UPS system connected to a HRG power source should be specified to have a rectifier input isolation transformer to prevent MOV failure during a ground fault in the input power distribution system. UPS are often supplied with MOVs connected line-to-ground to protect the rectifier power electronic devices.
- o When applying a three-phase input/output UPS module with separate bypass input to a 480 V or 600 V HRG power source, both the UPS inverter output transformer and the bypass transformer should be high resistance grounded. If the UPS output is solidly grounded while the bypass is HRG, the critical load could be compromised during an UPS output ground fault. Most 480 V and 600 V UPS suppliers offer the option of high resistance grounding the UPS.
- o When high resistance grounding parallel three-phase UPS modules with a shared output neutral, use 4-pole breakers to isolate the output of each UPS module.
- o It is suggested that UPS manufacturers consider the HRG practice used by generator suppliers, in which the parallel output bus is grounded through an artificial neutral zig-zag grounding transformer and NGR. Then, 3-pole module isolation breakers could be used instead of 4-pole.
- o For 480 V and 600 V submerged pumps, where it is desired to have sensitive ground fault detection of feeder insulation failure in the submerged liquid, a sensitive ground fault relay is suggested. Commercially available 600 V ground fault relays are available with 30 mA pickup for more sensitive equipment protection.
- o The design of a HRG system should incorporate a backup ground fault protection scheme to limit damage in the event that the system ground fault escalates into a double line to ground fault, or if the neutral ground resistor becomes shorted.
- o Worker training, with periodic review, is necessary to ensure that personnel are aware of the operation of a HRG system, and of the procedures required for safe operation and maintenance.
- o The design of a HRG system should include adequate ground current sensing equipment so that the location of the ground fault can be identified in a timely manner. In addition, a clear and logical ground fault operating procedure and supplemental ground tracking equipment

should be provided to assist workers in locating and isolating ground faults.

VII. REFERENCES

- [1] J.R. Dunki-Jacobs, "The Reality of High-Resistance Grounding," *IEEE Transactions on Industry Applications*, vol IA-13, pp 469-475, Sept/Oct 1977
- [2] D.L. Beeman, Ed., *Industrial Power Systems Handbook*, New York: McGraw-Hill, 1955, pp 337-338, 286-289.
- [3] J.P. Nelson, "System Grounding and Ground Fault Protection in the Petrochemical Industry: A Need for a Better Understanding," *IEEE Transactions on Industry Applications*, vol 38, pp 1633-1640, Nov/Dec 2002.
- [4] W.C. Bloomquist, K.J. Owen and R.L. Gooch, "High-Resistance Grounded Power Systems – Why Not?" *IEEE Transactions on Industry Applications*, vol IA-12, pp 574-580, Nov/Dec 1976.
- [5] J.R. Dunki-Jacobs, "The Effects of Arcing Ground Faults on Low-Voltage System Design" *IEEE Transactions on Industry Applications*, vol IA-8, pp 223-230, May/June 1972.
- [6] C.A.A. MacPhee, "Ground Fault Protection for Ungrounded Distribution Systems," *Conference Record of IEEE Industry Applications Society Annual Meeting*, vol 26-B, pp 630-637, 1975.
- [7] D.S. Baker, "Charging Current Data for Guesswork-Free Design of High Resistance Grounded Systems," *IEEE Transactions on Industry Applications*, vol IA-15, pp 136-140, Mar/Apr 1979.
- [8] B. Bridger, Jr., "High-Resistance Grounding," *IEEE Transactions on Industry Applications*, vol IA-19, pp 15-21, Jan/Feb 1983.
- [9] G.N. Wang, W.M. Moffatt, L.J. Vegh, F.J. Veicht, "High-Resistance Grounding and Selective Ground Fault Protection for a Major Industrial Facility," *IEEE Transactions on Industry Applications*, vol IA-20, pp 978-985, July/Aug 1984.
- [10] J.R. Dunki-Jacobs, "The Historical Development of Neutral-Grounding Practices," *IEEE Industry Applications Magazine*, vol 3, issue 2, pp 10-20, March/April 1997.
- [11] J.P. Nelson, P.K. Sen, "High Resistance Grounding of Low-Voltage Systems: A Standard for the Petroleum and Chemical Industry," *IEEE Transactions on Industry Applications*, vol 35, pp 941-948, July/Aug 1999.
- [12] J.P. Nelson, C. Satish, "Reducing Electrical Hazards in Process Industry by High Resistance Neutral Earthing," *Proceedings of 2000 IEEE IAS Workshop on Electrical Safety in Industry*, pp 83-83.
- [13] J.C. Das, R.H. Osman, "Grounding of AC and DC Low-Voltage and Medium-Voltage Drive Systems," *IEEE Transactions on Industry Applications*, vol 34, pp 205-216, Jan/Feb 1998.
- [14] G.L. Skibinski, B.M. Wood, J.J. Nichols, L.A. Barrios, "Effect of Adjustable-Speed Drives on the Operation of Low-Voltage Ground Fault Indicators," *IEEE Transactions on Industry Applications*, vol 37, pp 1423-1437, Sept/Oct 2001.
- [15] R.M. Tallam, D.W. Schlegel, F.L. Hoadley, "Failure Mode for AC Drives on High Resistance Grounded Power Systems," *Twenty-First Annual IEEE Applied Power*

Electronics Conference and Exposition, pp 1587-1591. March 2006.

- [16] R.E. Cossé, Jr., J.E. Bowen, W.H. Nichols, "Is Selectivity Achieved in Critical Low-Voltage UPS and Standby Generator Power Circuits?" *IEEE Transactions on Industry Applications*, vol 37, pp 1140-1151, July/Aug 2001.
- [17] IEEE 142-1991, *IEEE Recommended Practice for Grounding of Industrial and Commercial Power Systems (Green Book)*, New York, NY: IEEE.
- [18] ANSI/NEMA MG 1-2003, Revision 1-2004, *Motors and Generators*, Rosslyn, VA: NEMA
- [19] IEEE 141-1993, *IEEE Recommended Practice for Electric Power Distribution for Industrial Plants (Red Book)*, New York, NY: IEEE.
- [20] IEEE 242-2001, *IEEE Recommended Practice for Protection and Coordination of Industrial and Commercial Power Systems (Buff Book)*, New York, NY: IEEE.

VIII. VITA

David Murray received his B.Eng. degree in Electrical Engineering from McMaster University, Hamilton, Ontario, Canada in 1980. He began working as a drive systems engineer then switched to the UPS industry where he has held positions in application engineering, sales engineering, sales management and engineering management. He was a sales manager for at I-Gard (formerly IPC Resistors), helping consulting engineers apply and specify resistance grounding and relaying for low voltage and medium voltage power distribution systems. Mr. Murray is currently Marketing Manager, LV MCC and MV Equipment at Schneider Electric in Toronto, Ontario, Canada. He is a registered professional engineer in the province of Ontario.

John Dickin received his B.Sc. degree in Electrical Engineering from the University of Calgary in 1974. He has worked in various industries including manufacturing, electric utilities, gas transmission, oil refining, steel manufacturing, and petrochemical manufacturing. In 2001, Mr. Dickin formed Dickin Engineering Inc., and offers power systems expertise to a variety of industries. Mr. Dickin is a member of IEEE and the Association of Professional Engineers, Geologists and Geophysicists of Alberta. He is also an active participant and member in the committees developing the Objective Based Industrial Electrical Code in Canada, and has participated in the writing of the IEEE 1566 Standard for Adjustable Speed AC Drive Systems.

Robert A. Hanna received the B.Sc. degree from the University of Basra, Iraq in 1971, M.Sc. Degree (with Distinction) from Queen Mary College, University of London, England in 1973 and Ph. D. degree from Imperial College of Science and Technology, University of London, England in 1977, all in electrical engineering. Following a short teaching career, in 1981 he joined Petro Canada (formerly Gulf Canada) as a central engineering specialist providing technical support to the refineries in implementing capital projects and equipment selection. In 1995, he founded RPM Engineering Ltd., a certified consulting company in Ontario, Canada specializing in Adjustable Speed Drive applications, power quality studies, emergency shutdown equipment and equipment failure investigations.

Dr. Hanna is registered professional engineer in the

provinces of Ontario, Alberta and British Columbia, Fellow of the Institute of Electrical and Electronics Engineers (FIEEE), a Fellow of the Institution of Electrical Engineers (FIEE), UK and a Fellow of the Engineering Institute of Canada (FEIC). He is President of IEEE Canada and IEEE Director (Region 7) for 2006-2007.

Tom Morin completed his electrician's apprenticeship while serving in the Canadian Armed Forces in the 1980's. After working as an industrial electrician in western Canada, Tom completed the Industrial Instrumentation Technology program

at the Southern Alberta Institute of Technology. He received additional certification as an Engineering Technologist and Electronics Technician from the Alberta Society of Engineering Technologists in 1999. Since leaving the Armed Forces, Tom has held a variety of project management and technical roles within the oil and gas industry in western Canada and internationally. Presently, he manages the electrical services portfolio for Petro-Canada in the province of Alberta, Canada, and provides technical support to the corporation's upstream facilities throughout western Canada.