

# Grid and Ribbon Resistors

## Application

Post Glover's grid and ribbon resistors are ideal for medium to high amperage conditions in either AC or DC applications. The most common usages are for motor control for braking and speed regulation, but also can be incorporated into neutral grounding, harmonic filtering and load bank solutions.

Both grid and ribbon styles are ideal where continuous operation under extreme conditions is common. The element material, resistor grade stainless steel, is especially well suited for continuous duty and minimal resistance fluctuation. Their rugged design makes them a natural fit for high vibration applications such as material handling and mining duty.

## Stamped Grid Resistors

The unique design of Post Glover's stamped grid resistor provides you with much higher wattage per bank than other brands. As a result, your equipment will require fewer resistors, saving you both space and cost.

The superior construction produces savings in maintenance costs and reduced downtime. This built-in ruggedness makes it ideal for the high shock and vibration of heavy material handling applications such as overhead cranes, mining equipment, construction tower cranes, pumps and many other starting, speed regulating and dynamic braking applications.

All banks are rated 1000 volts AC or DC, and up to 185 amps continuous based on a 375°C rise. Isolated sections are available for three phase applications, as are special tapered ratings using custom grid combinations.

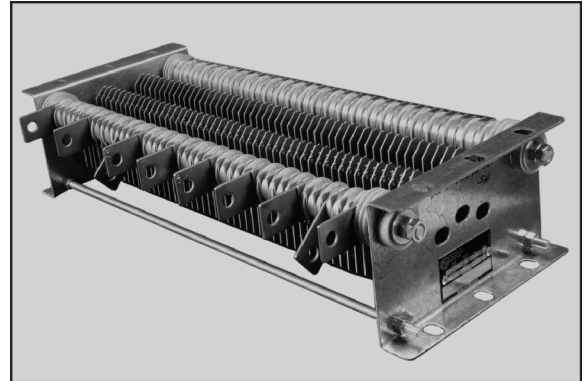

### Features

- Low temperature coefficient stainless steel elements and stainless steel terminals for long-lasting reliability.
- Positive grid-to-grid connections, with no current carrying washers or spacers which can cause failure.
- Tig welded connections to eliminate damaging hot spots.

## Stainless Steel Ribbon Resistors

The Stainless Steel Ribbon Resistors feature a 4-inch-wide stainless steel element that is a serpentine formed from one continuous strip up to thirty feet long. A special Type-406 alloy is used to limit the increase in resistance to only 6% at rated current (375°C rise).

Heavy 304 stainless terminal plates are both mechanically clamped and TIG welded to the element and feature a 2-hole NEMA bolt pattern for 1/2" hardware. Extra terminal plates allow quick field adjustments and flexibility in designing.

The element and terminals are rigidly supported for high vibration, high temperature applications in corrosive environments. PG ribbon resistors are double insulated to ground and are rated 1,500 volts. Perfect for high horsepower, high voltage motors.

Standard "Mill Bank" dimensions and eight popular amp ratings (200, 225, 260, 300, 350, 400, 450 and 525) interchange easily with all major brands. Slotted mounting holes assure proper fit.

High "watts per bank" reduces the number of banks required for large Wound Rotor Motor applications such as Phosphate Slurry Pumps, Water and Sewage Pumps, Mine Hoists, Overhead Cranes and Mill Drives.

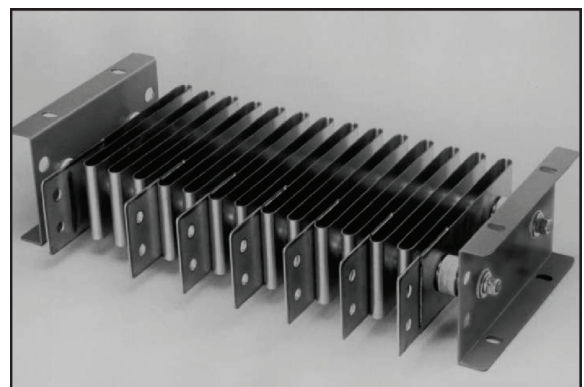

### Features

- Stainless-Steel Terminals
- Double Insulated, rated 1500V
- Interchange with all major brands

**Custom designs are available upon request.  
Contact Post Glover for details.**

324 Governor Road • Braeside, Victoria 3195 • AUS  
Phone: +61 (0)3 9587 4099 • Fax: +61 (0)3 9587 4130  
www.postgloverasia.com

Quality System Certified to ISO 9001

© 2010 Post Glover Resistors, Inc.

4750 Olympic Blvd. • Erlanger, KY 41018 • USA  
Phone: 800-537-6144 / 859-283-0778 • Fax: 859-283-2978  
www.postglover.com

Serving the Electrical Industry Since 1892



**Post Glover**

"The Resistor Specialists"



PGR Document #RE105-08

# Grid and Ribbon Resistors

## Ratings

POST GLOVER ELECTRICAL RATINGS FOR GRID AND RIBBON RESISTORS					
Post Glover No.	Total OHMS	Continuous AMPS	OHMS/TAP	Total No. of Terminals	Total Watts
PG-1	0.02	525A	0.004	6	5639W
PG-2	0.024	525A	0.004	7	6747W
PG-3	0.028	525A	0.004	7	7872W
PG-4	0.034	525A	0.005	7	9639W
PG-5	0.042	450A	0.006	7	8266W
PG-6	0.048	450A	0.006	8	9538W
PG-7	0.059	400A	0.008	7	9408W
PG-8	0.074	350A	0.009	8	9016W
PG-9	0.087	300A	0.012	7	7812W
PG-10	0.099	300A	0.012	8	8928W
PG-11	0.115	260A	0.014	8	7788W
PG-12	0.148	225A	0.016	9	7472W
PG-13	0.16	185A	0.023	8	5462W
PG-14	0.182	185A	0.023	9	6243W
PG-15	0.217	185A	0.023	10	7413W
PG-16	0.245	165A	0.033	10	6665W
PG-17	0.277	150A	0.031	10	6237W
PG-18	0.324	135A	0.036	10	5905W
PG-19	0.36	135A	0.036	10	6561W
PG-20	0.416	120A	0.042	10	5990W
PG-21	0.478	120A	0.063	8	6889W
PG-22	0.552	110A	0.069	9	6679W
PG-23	0.648	100A	0.072	10	6480W
PG-24	0.756	90A	0.084	10	6124W
PG-25	0.9	80A	0.1	10	5760W
PG-26	1	80A	0.1	10	6400W
PG-27	1.2	80A	0.15	9	7680W
PG-28	1.4	75A	0.168	9	7875W
PG-29	1.55	70A	0.186	9	7595W
PG-30	1.798	70A	0.186	10	8810W
PG-31	2.128	63A	0.228	10	8446W
PG-32	2.6	50A	0.3	9	6500W
PG-33	3.224	44A	0.372	9	6242W
PG-34	3.968	44A	0.496	9	7862W
PG-35	5.1	38A	0.6	9	7364W
PG-36	6.592	30A	0.824	9	6307W
PG-37	8.192	28A	1.024	9	6423W
PG-38	10.24	25A	1.024	11	6400W
PG-39	12.88	20A	1.288	11	5088W
PG-40	15.456	18A	1.288	13	4946W

324 Governor Road • Braeside, Victoria 3195 • AUS  
 Phone: +61 (0)3 9587 4099 • Fax: +61 (0)3 9587 4130  
[www.postgloverasia.com](http://www.postgloverasia.com)

Quality System Certified to ISO 9001

© 2010 Post Glover Resistors, Inc.

4750 Olympic Blvd. • Erlanger, KY 41018 • USA  
 Phone: 800-537-6144 / 859-283-0778 • Fax: 859-283-2978  
[www.postglover.com](http://www.postglover.com)

Serving the Electrical Industry Since 1892



PGR Document #RE105-08

# Grid and Ribbon Resistors

## Post Glover Resistors — The Proven Replacement

With the Post Glover “Core 40 Plan,” you can replace virtually every big name in the power resistor business – and you can count on shipment in as few as five days. Our line of 40 resistor cores replaces hundreds of G.E., Cutler Hammer, Hubbell, Westinghouse, and Square D resistors. Replacement is as simple as unbolting the old resistor and bolting on the corresponding “Core 40 Plan” resistor.

### How to Use this Chart:

First, locate the manufacturer's column and catalog number of the resistor you're replacing. The appropriate Post Glover replacement resistor is located on the same line in the far left column. If you're unable to locate the resistor you require, or have a special application, call us for assistance. Contact the factory for a more in-depth IPC cross reference guide.

THE “CORE 40 PLAN” REPLACEMENT CHART									
Post Glover Core No.	Total OHMS @ 25°C +/- 10%	Continuous AMPS @ 375°C	SUGGESTED REPLACEMENT FOR:						
			IPC	Cutler Hammer	Hubbell	Westinghouse	General Electric	Square D	Challenger
PG-1	0.020	525							TW500D
PG-2	0.024	525					IC9141-A004A103		
PG-3	0.028	525						TW430D	
PG-4	0.034	525	SSR525	G14WL03	53357-006				
PG-5	0.042	450		G14WL04			IC9141-A002A101	TW360D	
PG-6	0.048	450	SSR450	G14WL05	53357-005				
PG-7	0.059	400	SSR400	G14WL06	53357-004		IC9141-A002A102		
PG-8	0.074	350	SSR350		53357-003			TW280D	
PG-9	0.087	300							
PG-10	0.099	300	SSR300		53357-002		IC9141-A002A103		
PG-11	0.115	260	SSR260	G11WL12	53357-001 53357-024			TW220D	
PG-12	0.148	225	SSR225		53357-023				
PG-13	0.160	185		G11WL16			IC9141-A001A101		
PG-14	0.182	185						TW180D	
PG-15	0.217	185	SSG190	G11WL20	53357-022				
PG-16	0.245	165	SSG160	G11WL25		1776163	IC9141-A001A102	TW150D	112A155
PG-17	0.277	150			53357-021				112A140
PG-18	0.324	135		G11WL32	53357-020	1776574 1776164		TW120D	
PG-19	0.360	135	SSG135		53356-023				
PG-20	0.416	120		G11WL40	30856-022		IC9141-A001A103		112A120
PG-21	0.478	120	SSG120	G11W350	30856-021	1777575 1776165		TW100D	112A110
PG-22	0.552	110			30856-018 30856-017				
PG-23	0.648	100		G11WL62	30856-016	1776166	IC9141-A001A104		112A90
PG-24	0.756	90		G11WL80	30856-015	1776167		TW85D	
PG-25	0.900	80							
PG-26	1.000	80		G11WL100	30856-011	1776168		TW72D	112A75
PG-27	1.200	80	SSG83	G11WL125	30856-010	1777576	IC9141-A001A205		
PG-28	1.400	75	SSG75		30856-009			TW62D	112A63
PG-29	1.550	70		G11WL160	30856-007	1777577 1776169			
PG-30	1.798	70	SSG70				IC9141-A001A206		
PG-31	2.128	63	SSG63	G11WL200	30856-006	1777487			112A53
PG-32	2.600	50		G11WL250		1776179	IC9141-A001A207	TW50D	
PG-33	3.224	44		G11WL320					112A44
PG-34	3.968	44	SSG42	G11WL400		1776180 1777579	IC9141-A001A208	TW42D	112A38
PG-35	5.100	38	SSG38	G11WL500		1776181		TW37D	
PG-36	6.592	30		G11WL625		1776182	IC9141-A001A209	TW32D	112A24 112A37
PG-37	8.192	28		G11WL800		1776170			112A32
PG-38	10.240	25	SSG25			1777581 1776183	IC9141-A001A210	TW27D	
PG-39	12.880	20							
PG-40	15.456	18		G11WL1440		1777582 1776184		TW21D	

\*Please note continuous current rating for your application.

324 Governor Road • Braeside, Victoria 3195 • AUS  
 Phone: +61 (0)3 9587 4099 • Fax: +61 (0)3 9587 4130  
 www.postgloverasia.com

Quality System Certified to ISO 9001

© 2010 Post Glover Resistors, Inc.



**Post Glover**  
 “The Resistor Specialists”



Serving the Electrical Industry Since 1892

4750 Olympic Blvd. • Erlanger, KY 41018 • USA  
 Phone: 800-537-6144 / 859-283-0778 • Fax: 859-283-2978

www.postglover.com

PGR Document #RE105-08

# Grid and Ribbon Resistors

## Dimensions and Terminal Details

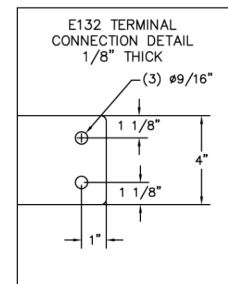
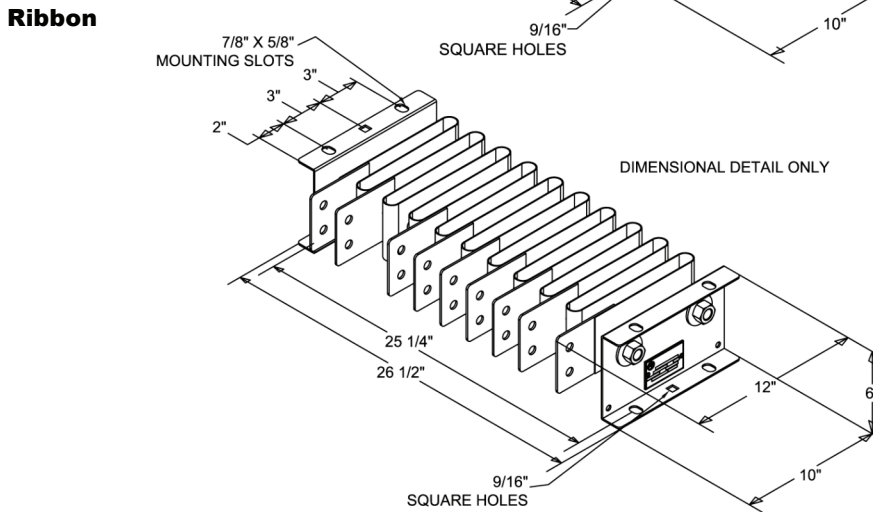
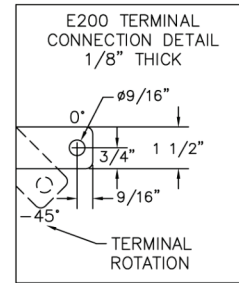
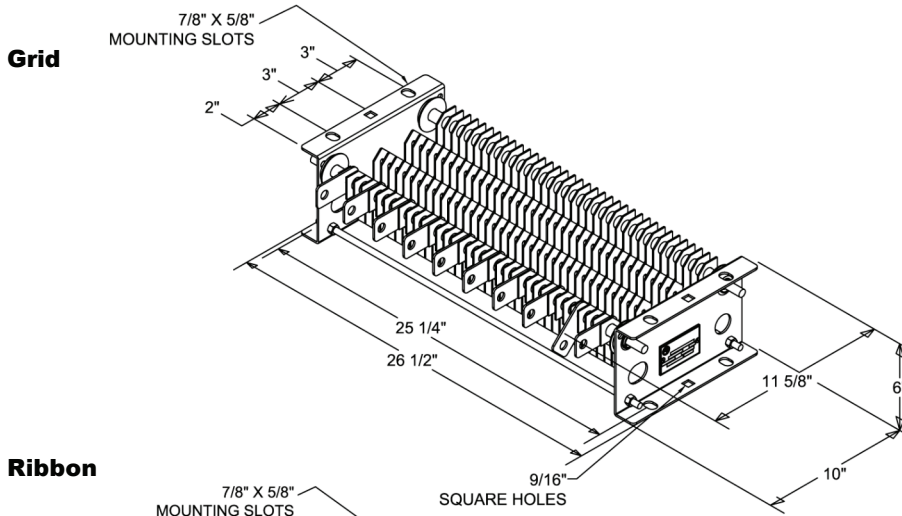

### Enclosure

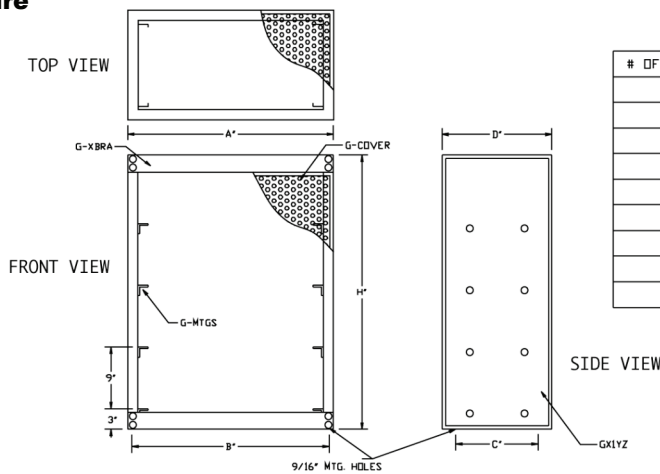

# OF BANKS	H"
1	13"
2	22"
3	31"
4	40"
5	49"
6	58"
7	67"
8	76"
9	85"

DEPTH D"	MTG HOLE C"
16"	12"
18"	14"
20"	16"

WIDTH A"	B"
30"	28 3/4"
29"	27 1/2"

324 Governor Road • Braeside, Victoria 3195 • AUS  
Phone: +61 (0)3 9587 4099 • Fax: +61 (0)3 9587 4130  
www.postgloverasia.com

Quality System Certified to ISO 9001

© 2010 Post Glover Resistors, Inc.

4750 Olympic Blvd. • Erlanger, KY 41018 • USA  
Phone: 800-537-6144 / 859-283-0778 • Fax: 859-283-2978  
www.postglover.com

Serving the Electrical Industry Since 1892



PGR Document #RE105-08